

# VISO SYSTEMS

## BaseSpion

### User Manual

Revision: Decemeber 2023



VISO  
BaseSensor

VISO  
BaseSpion

---

*Congratulations on purchasing your new Viso Systems product. Before using this product, please read the Safety Information.*

*This manual contains descriptions and troubleshooting necessary to install and operate your new Viso Systems product. Please review this manual thoroughly to ensure proper installation and operation.*

*For news, Q&A and support at Viso Systems, visit our website at [www.visosystems.com](http://www.visosystems.com)*

*Other manuals in this series (the latest version can be downloaded from [www.visosystem.com](http://www.visosystem.com)):*

- Guidelines - building a lighting laboratory
- BaseSpion Assembly Manual
- LabFlicker User Manual
- VISO Reference CALI-T50 User guide (calibration light source)

## Contents

<b>1.</b>	<b>Safety Information</b> .....	<b>4</b>
1.1.	Preventing Electric Shocks .....	4
<b>2.</b>	<b>Disposing of this Product</b> .....	<b>4</b>
<b>3.</b>	<b>Introduction</b> .....	<b>4</b>
3.1.	About this Document .....	4
3.2.	About the BaseSpion.....	4
<b>4.</b>	<b>Product dimensions</b> .....	<b>5</b>
<b>5.</b>	<b>Packaging and Weight</b> .....	<b>6</b>
<b>6.</b>	<b>BaseSpion Items</b> .....	<b>7</b>
<b>7.</b>	<b>Shipping Packages</b> .....	<b>7</b>
<b>8.</b>	<b>Room Considerations</b> .....	<b>7</b>
8.1.	General Laboratory Considerations .....	7
8.2.	Sensor Distance.....	7
<b>9.</b>	<b>Room and Table Dimensions</b> .....	<b>8</b>
<b>10.</b>	<b>Goniometer ‘Dark Zone’</b> .....	<b>9</b>
10.1.	The back wall .....	10
10.2.	Installing on a wall-mounted tabletop.....	11
10.3.	LabDisc standard baffle.....	11
<b>11.</b>	<b>Installation</b> .....	<b>12</b>
11.1.	Mechanical installation .....	12
11.2.	Software Installation.....	12
11.3.	Connect Power.....	13
11.4.	AC Power Supply Cable Plug .....	13
11.5.	Checking the fuse.....	14
11.6.	Connect USB .....	14
11.7.	Connecting the BaseSensor .....	15
11.8.	Connecting the C-plane Goniometer .....	15
11.9.	Connecting Light Source Power .....	15
11.10.	AC Power Supply Cable Plug .....	16
11.11.	Connecting Diagram.....	16
11.12.	Mounting and Alignment of the Light Source .....	17
<b>12.</b>	<b>Mounting of Fixtures with a Static Base</b> .....	<b>19</b>
<b>13.</b>	<b>Making Measurements</b> .....	<b>20</b>
<b>14.</b>	<b>Attaching the E27 Lamp Holder</b> .....	<b>20</b>
<b>15.</b>	<b>BaseSensor sensitivity range</b> .....	<b>22</b>
<b>16.</b>	<b>Specifications</b> .....	<b>23</b>
<b>17.</b>	<b>Appendix 2: Laboratory Checklist</b> .....	<b>25</b>

---

# 1. Safety Information

*Warning! This product is not for household use.*

Read this manual before installing and operating the BaseSpion, follow the safety warnings listed below, and study all the cautions in the manual.

## 1.1. Preventing Electric Shocks



Make sure the power supply is always grounded.

Use a source of AC power that complies with the local building and electrical codes, that has both overload and ground-fault protection.

If the controller or the power supply are in any way damaged, defective, wet, or show signs of overheating, disconnect the power supply from the AC power and contact Viso Service for assistance.

Do not install or use the device outdoors. Do not spray with or immerse in water or any other liquid.

Do not remove any covers or attempt to repair the controller or the power supply. Refer any service to Viso.

## 2. Disposing of this Product



Viso Systems products are supplied in compliance with Directive 2012/19/EU on waste - electrical and electronic equipment (WEEE) together with the RoHS Directive 2011/65/EU with amendments 2015/863. Help preserve the environment! Ensure that this product is recycled at the end of its lifetime. Your supplier can give details of local arrangements for the disposal of Viso Systems products.

## 3. Introduction

### 3.1. About this Document

These guidelines describe the installation process of the BaseSpion followed by the typical measurements of various light sources.

### 3.2. About the BaseSpion

The BaseSpion is a revolutionary new far field goniometer system with a spectrometer sensor that makes it possible to measure all photometric measurements quickly and efficiently. The Light Inspector software enables it to quickly measure, save and export the newly obtained data.

© 2007 Viso Systems ApS, Denmark

All rights reserved. No part of this manual may be reproduced, in any form or by any means, without permission in writing from Viso Systems ApS, Denmark. Information subject to change without notice. Viso Systems ApS and all affiliated companies disclaim liability for any injury, damage, direct or indirect loss, consequential or economic loss or any other loss occasioned by the use of, inability to use or reliance on the information contained in this manual.

## 4. Product dimensions

### Goniometer

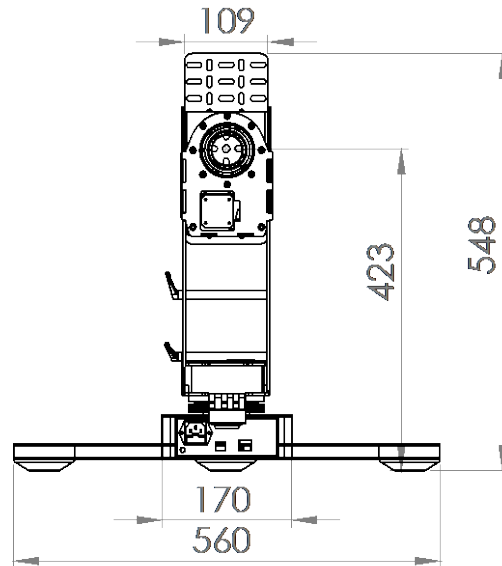

### Sensor

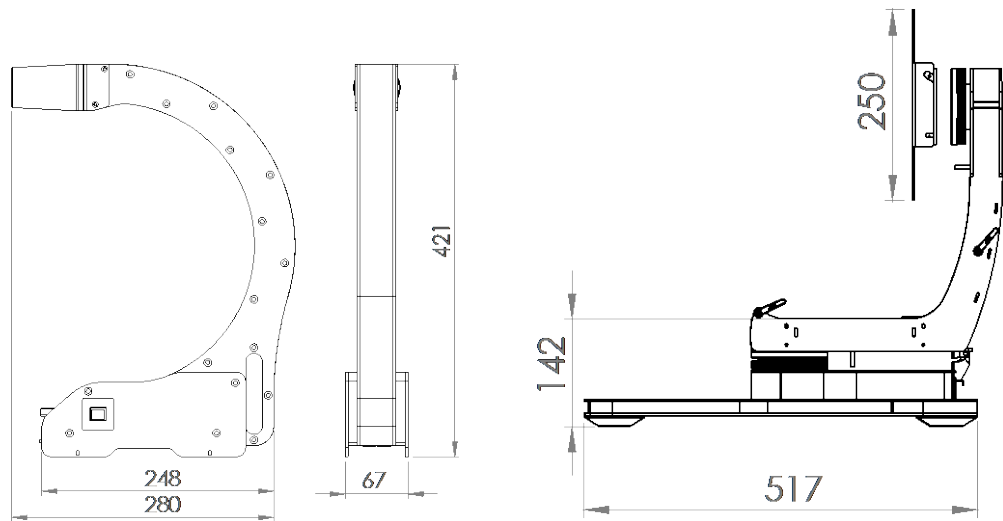

### Rail I+II+III

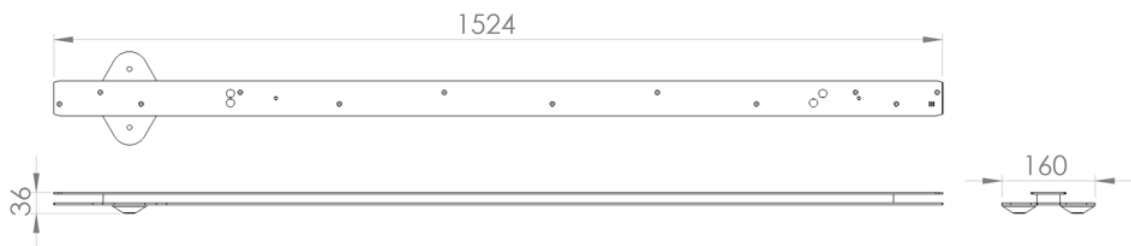

---

# 5. Packaging and Weight

The BaseSpion consist of 5 main assemblies as shown below.

Base – 14 kg



2/3 x sensor rail – 4 kg (20 kg)



Sensor 6 kg



Tower 4 kg



E27 lamp holder – 0,5 kg



E27 Adapters 0,2 kg



## 6. BaseSpion Items

- Base
- 3 x Sensor rails
- Tower
- Sensor
- Bulb holder with E27, E14, G10 and B22 adaptor.
- 2 m IEC power cord
- 5 m USB cable
- 7,5 m RJ45 cable for connection the Sensor
- Screws and cables for assembly

## 7. Shipping Packages

Shipping Packages	Shipping Dimensions	Shipping Volume	Weight
1. Sensor	500 x 500 x 200 mm	0.050 m <sup>3</sup>	6 kg
2. Base + Tower	600 x 600 x 350 mm	0.126 m <sup>3</sup>	19 kg
3. Rails + Assemblies	1,650 x 280 x 280 mm	0.129 m <sup>3</sup>	20 kg

Total shipping weight: 45 kg.

Total shipping CBM: 0.305 m<sup>3</sup>

The shipment is done in a total of 3 packages.

## 8. Room Considerations

### 8.1. General Laboratory Considerations

See Viso publication "Guidelines - building a lighting laboratory". The most up-to-date version can be downloaded from

[https://data.visosystems.com/content/manuals/guidelines\\_building\\_a\\_lighting\\_laboratory.pdf](https://data.visosystems.com/content/manuals/guidelines_building_a_lighting_laboratory.pdf).

### 8.2. Sensor Distance

The BaseSpion is a far field system, which means the distance between the light source and the sensor should be at least 8 x diameter of the lamp as shown below.

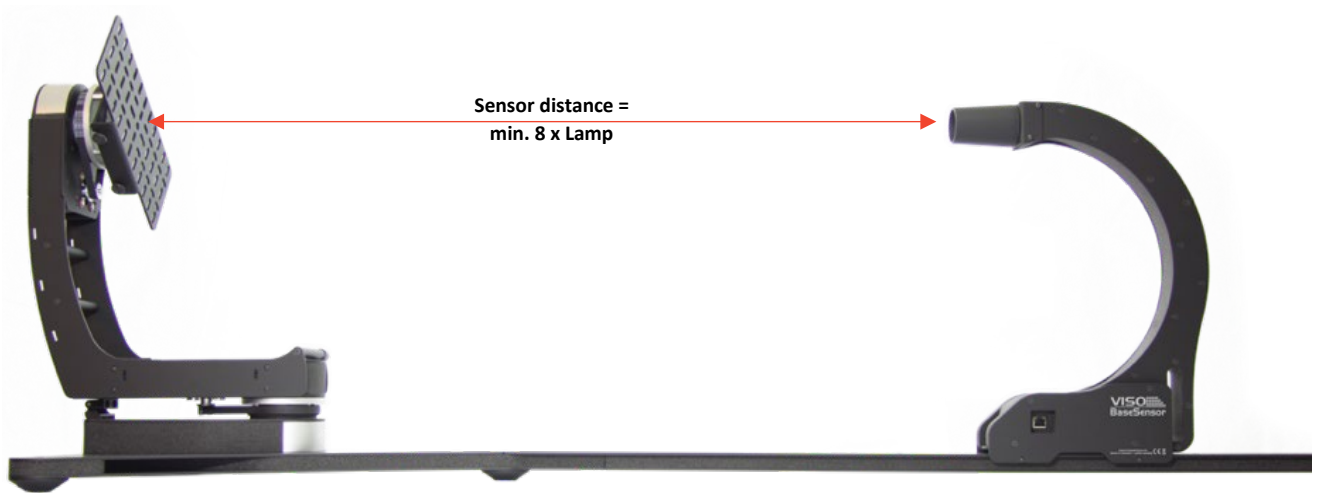

For example, for a lamp with a 20 cm diagonal illuminating surface, the distance from center of rotation of the gonio to sensor should be at least 160cm (20cm x 8). See more in “Guidelines - building a lighting laboratory”.

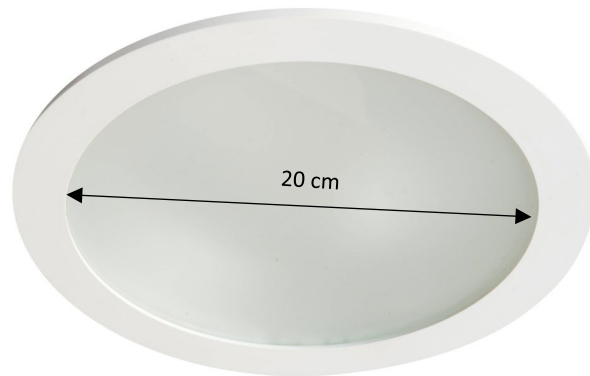

Note ! The “Lamp diameter” is only the light emitting part of the lamp.

Adapting the distance is important. At too short distances (below 8 times the maximum luminous dimension), the sensor will not be able to “see” the whole light source. Sticking to the recommended distances is important because it

- optimizes the signal-to-noise ratio – see graph in section 14.
- limits stray light especially for directional light sources
- lowers the sensor integration time hence also the total measurement time.

## 9. Room and Table Dimensions

The Sensor Rail that attaches to the Goniometer Base comes standard in three parts giving you the option of three different setups, depending on your needs and what your room allows.



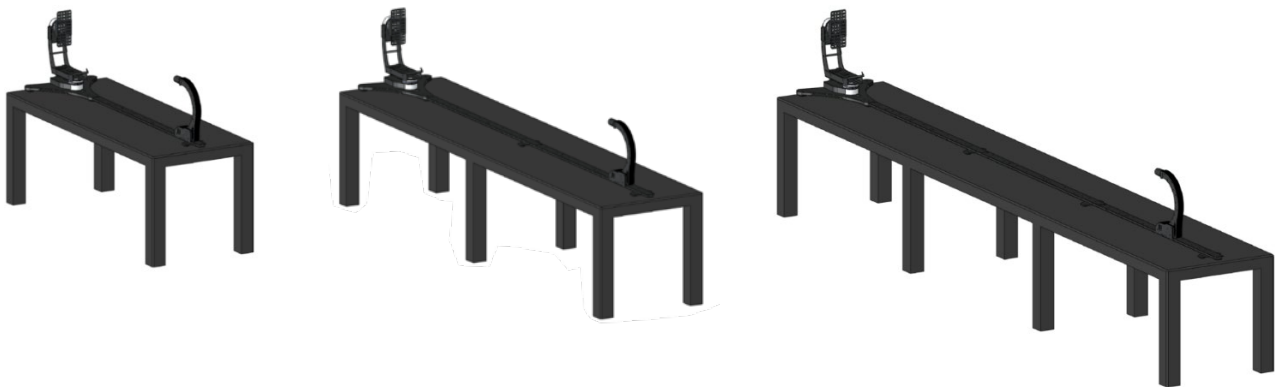

In the chart below is given the max light source size for each rail position.

Rail position	Light Source Diameter	Sensor Distance	Table Length	Room Length	Rail
1	40 mm	350 mm	2 m	3 m	I
2	60 mm	500 mm	2 m	3 m	I
3	90 mm	750 mm	2 m	3 m	I
4	120 mm	1000 mm	2 m	3 m	I
5	180 mm	1500 mm	2 m	3 m	I
6	240 mm	2000 mm	3.5 m	4.5 m	I+II
7	300 mm	2500 mm	3.5 m	4.5 m	I+II
8	360 mm	3000 mm	3.5 m	4.5 m	I+II
9	420 mm	3500 mm	5 m	6 m	I+II+III
10	540 mm	4500 mm	5 m	6 m	I+II+III

### Example

If you need to measure a light source with a diameter of 270 mm, you need to have Rail I and Rail II mounted, and the sensor should be slid to position 7 (sensor distance 2500 mm)

Room width: Recommended 100 cm or more (Minimum 60 cm depending on lamp size)

## 10. Goniometer ‘Dark Zone’

A room can be darkened either by painting the walls black or using a black curtain. A Molton stage fabric black curtain works better than a painted wall, as the folds in the curtain work as small light baffles trapping the light. In fact, in a narrow space **black painted walls are very difficult to make work**. Even if painted totally black, they still reflect light. This is a problem especially at sensor distances 3500 and 4500 mm. See more in “Guidelines - building a lighting laboratory”

Normally, when doing light measurements, a completely dark room is needed. But with the BaseSpion it is not a necessity for the whole room to be dark as the sensor

---

uses a special directional sensor. This means having only the goniometer in a dark zone will be sufficient, as shown below.

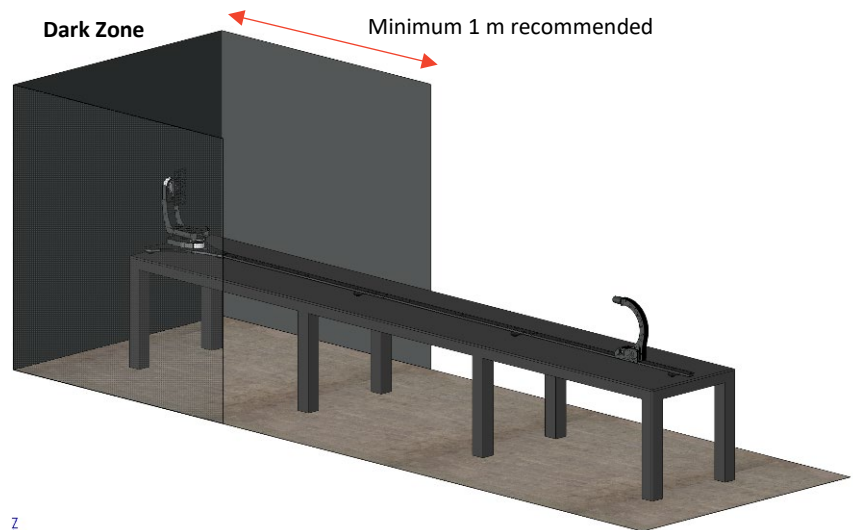

z

It is recommended the depth of the dark zone to be 1 meter or more.

([https://data.visosystems.com/content/manuals/guidelines\\_building\\_a\\_lighting\\_lab\\_oratory.pdf](https://data.visosystems.com/content/manuals/guidelines_building_a_lighting_lab_oratory.pdf)). Note: If you have the option to have a fully dark room, this should be your first choice.

### 10.1. The back wall

The back wall behind the goniometer is the most important wall, as the stray light from this wall will bounce stray back into the sensor. Make sure always to cover this wall with a richly folded stage Molton fabric in Black.



## 10.2. Installing on a wall-mounted tabletop

When installing the Basespion on wall-mounted table, the side wall gets particularly close to the photometrical center line (line between the sensor and the middle of the light source on the gonio).

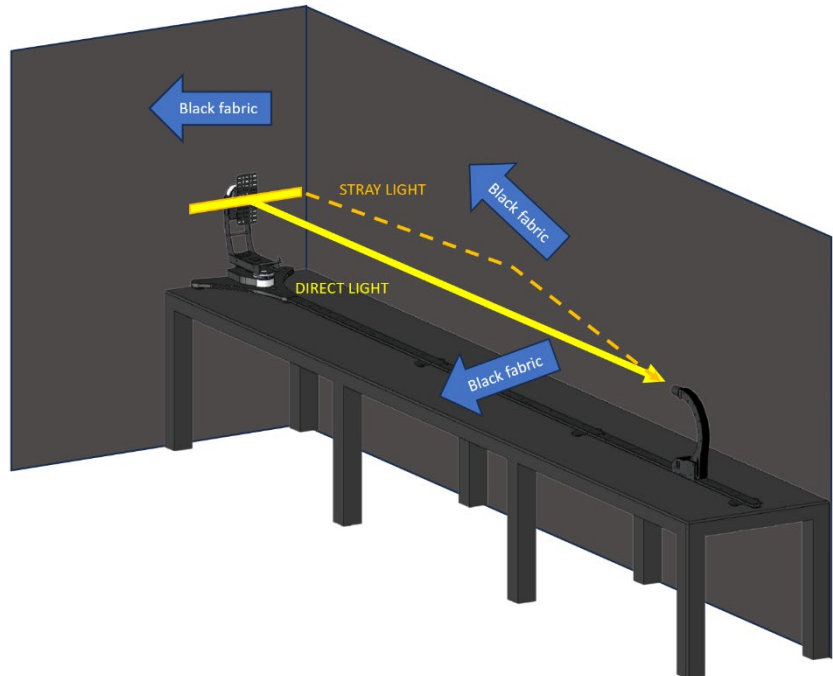

Make sure that the adjacent wall is also covered with Molton fabric in Black.

## 10.3. LabDisc standard baffle

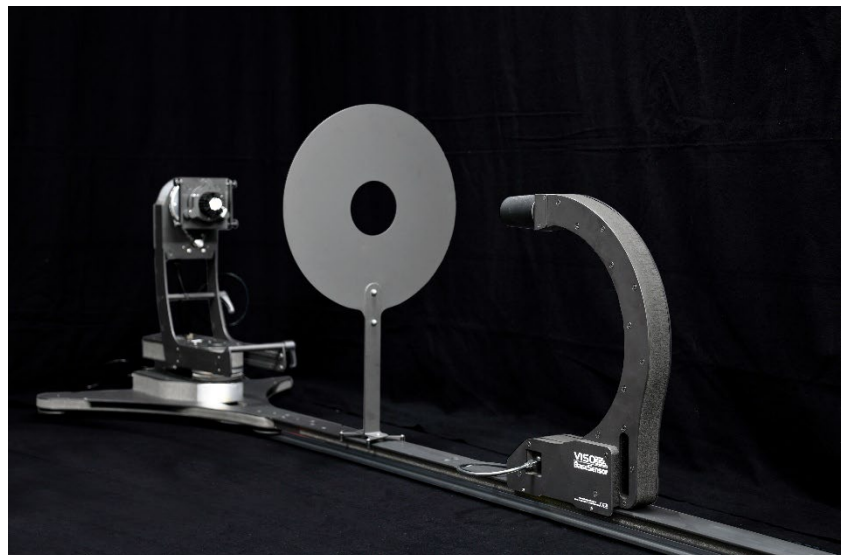

You may also consider the standard Viso accessory LabDisc to prevent straylight in your lab. This unit sits permanently on the tripod/LabRail stem and limits the sensor field-of-view to a minimum.

---

# 11. Installation

## 11.1. Mechanical installation

Use the special BaseSpion assembly manual for the mechanical assembly:

[https://data.visosystems.com/content/manuals/basespion\\_assembly\\_manual.pdf](https://data.visosystems.com/content/manuals/basespion_assembly_manual.pdf)

## 11.2. Software Installation

Before you can start using the BaseSpion, the “Viso Light Inspector” software must be installed. It is supported on all windows platforms.

Use the following link to download the latest version:

<http://www.visosystems.com/download-light-inspector/>

- 1) Please make sure the BaseSpion is not connected to the computer during software installation.
- 2) Run the .msi file and follow the installation instruction.

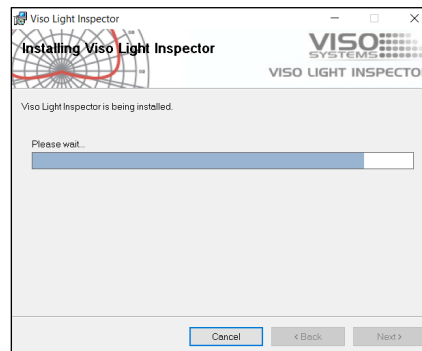

- 3) USB drivers are automatically installed.



Your measurements are not lost when updating to a newer version or uninstalling and reinstalling. All measurements will always remain in your document folder. If you want to remove all your measurements go to the 'Light Inspector' folder and delete them manually.

Folder location:

*C:\Users\'Username'\Documents\Viso Systems\Light Inspector*

Or if stored in dropbox:

*C:\Users\'username'\Dropbox*

### 11.3. Connect Power

The BaseSpion comes with a standard IEC power-in connector and with a standard euro power cable, but any power cable can be used as the BaseSpion supports any outlet voltage from 90-260VAC.

The power-in connector supplies power to the goniometer motor, power analyzer and the light source being measured. Which means the power feed to the system is also what is being delivered to the light source to be measured.



### 11.4. AC Power Supply Cable Plug



**Warning: Risk of an electric shock! Plug installation shall be performed by a qualified electrician.**

A grounding-type (earthed) power plug that fits the local power outlet must be used. You can acquire an IEC power cable with a suitable grounding-type plug from most of consumer electronics stores.

When installing the plug connect pins as follows:

- Yellow and green wire to grounding (earth)
- Blue wire to neutral
- Brown wire to live

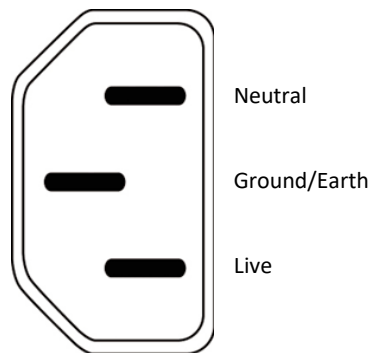

## 11.5. Checking the fuse

Just under the mains-in connector, there is a fuse and a replacement fuse in a small drawer. If the 'Power on' diode is not clearly blue, the fuse may be broken.

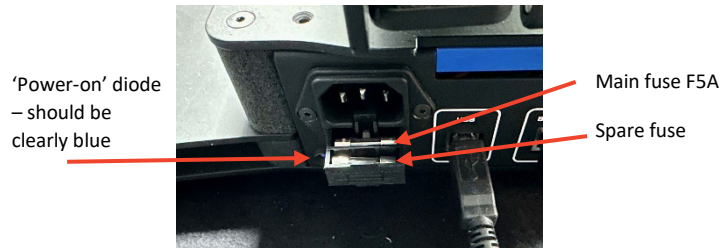

Remove the fuse from the rear pocket and insert the spare fuse from the front pocket. Remember to buy a new spare fuse – a fast-blow 5 A fuse.

## 11.6. Connect USB

The BaseSpion is connected to the computer using a USB connector type A to B. A 2-meter USB cable is included with the BaseSpion, however any USB cable supporting USB2.0 can be used.

The USB provides communication and power to the BaseSpion's main board processor. But to run power analyzer and spectrometer, you need to have power connected.



Start the "Viso Light Inspector" software after having connected the USB; the connection to the BaseSpion will be established automatically. A successful connection is shown with a green "Connected" icon in the upper right-hand corner of the 'Viso Light Inspector' software.

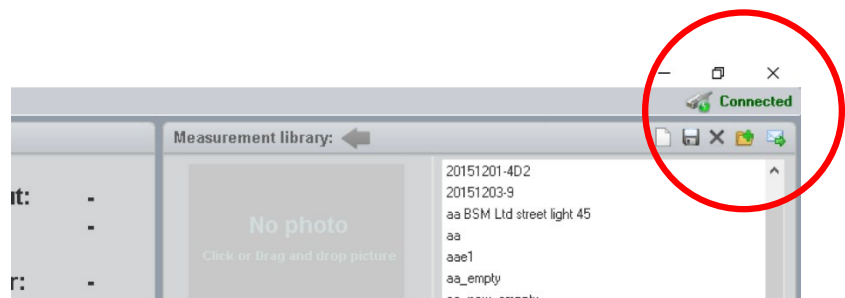

You can connect and disconnect the USB without restarting the "Viso Light Inspector" software, as the connection is always established automatically as soon as the USB connector is plugged in and vice versa.

### 11.7. Connecting the BaseSensor

The BaseSpion is connected to the LabSensor with a RJ45 cable.

A 7.5-meter RJ45 Cat5 shielded cable is supplied with the BaseSpion, but any shielded RJ45 cable can be used.



**Warning:** Do not connect the Sensor to the C-plane motor connector, this could damage the Sensor.

### 11.8. Connecting the C-plane Goniometer

The C-plane goniometer is connected to the BaseSpion base through a RJ45 cable. The BaseSpion will automatically detect the C-plane goniometer.

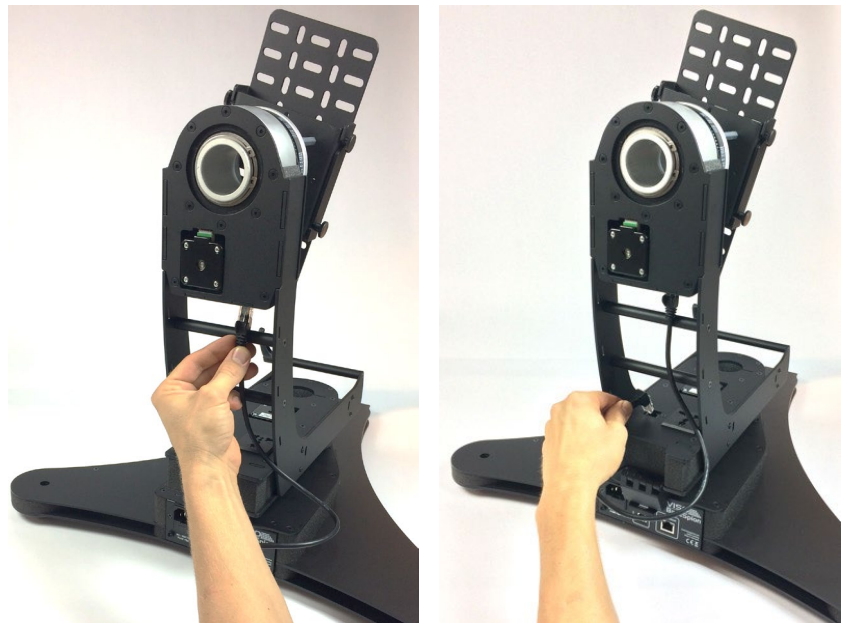

**Warning:** Do not connect the C-plane motor to the Sensor connector. This could damage the BaseSpion.

### 11.9. Connecting Light Source Power

The BaseSpion has a built-in power analyzer and power switch. The power switch is used when running in ambient light correction mode. So the lamp can be switched off before a measurement, so that the values of the ambient light can be obtained and subsequently subtracted from final measurements.



The maximum current supported by the lamp output is 3A, which is 660 W at 220 VAC and 330 W at 110 VAC.

#### 11.10. AC Power Supply Cable Plug



**Warning: Risk of electric shock! Plug installation shall be performed by a qualified electrician.**

A grounding-type (earthed) power plug that fits the local power outlet must be used. You can acquire an IEC power cable with a suitable grounding-type plug from most of consumer electronics stores.

When installing the plug connect pins as follows:

- Yellow and green wire to grounding (earth)
- Blue wire to neutral
- Brown wire to live

Good light measurements rely on stable main supply. If mains supply is insufficient the light source can be supplied via an external power supply. See more in the Light Inspector software manual.

#### 11.11. Connecting Diagram

Below there is the connection diagram showing the different connections in order to make the system operational.



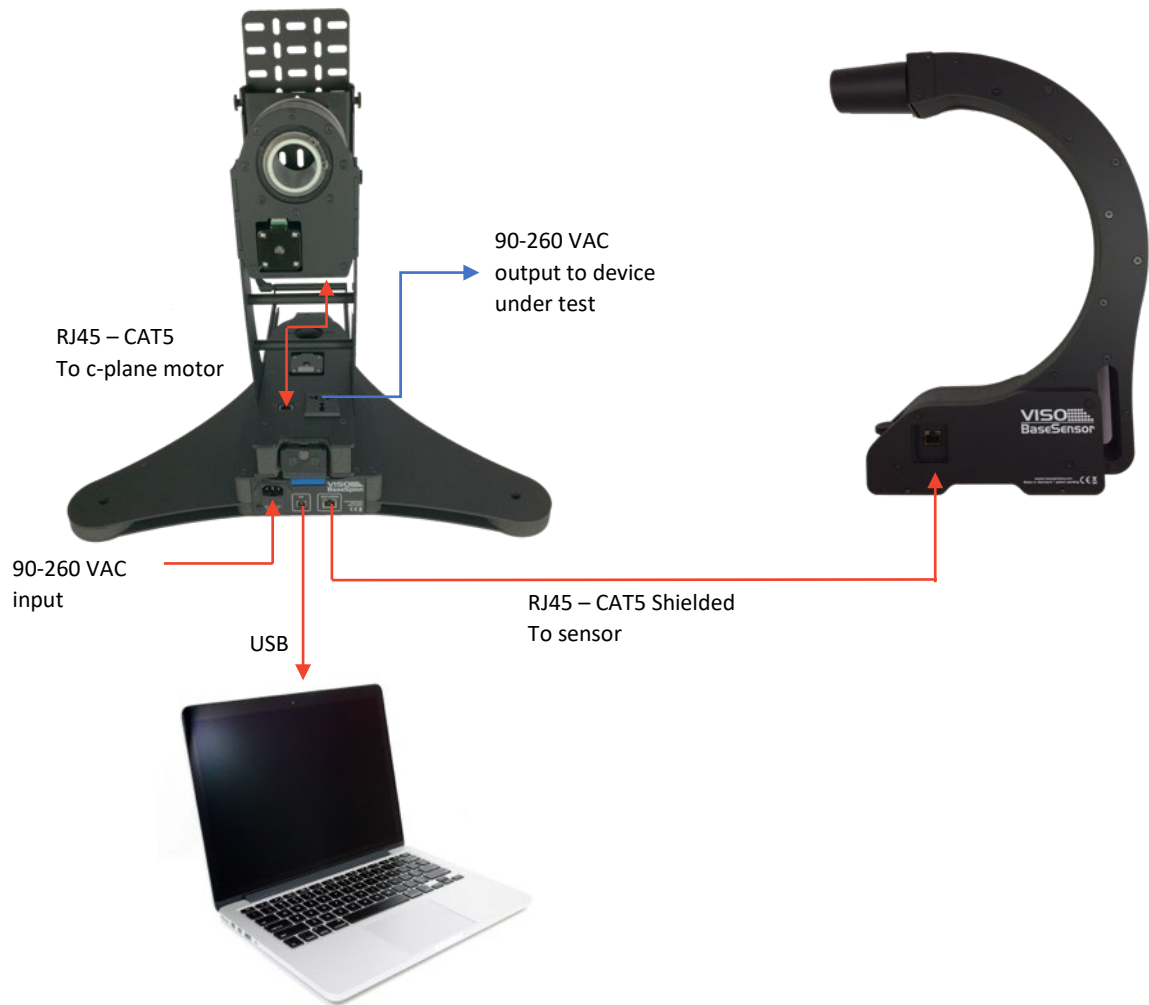

### 11.12. Mounting and Alignment of the Light Source

Aligning the lamp is key to ensuring a precise measurement. Cut outs in the top of the goniometer marks the center of rotation. All lamps must be carefully centered before measurement, like the picture below. The transparent disc imitates the center of a light source.

What is the “center of the light source” – read in the Light Inspector software manual, under “Photometric Center Guide”:

[https://data.visosystems.com/content/manuals/light\\_inspector\\_user\\_manual.pdf](https://data.visosystems.com/content/manuals/light_inspector_user_manual.pdf)

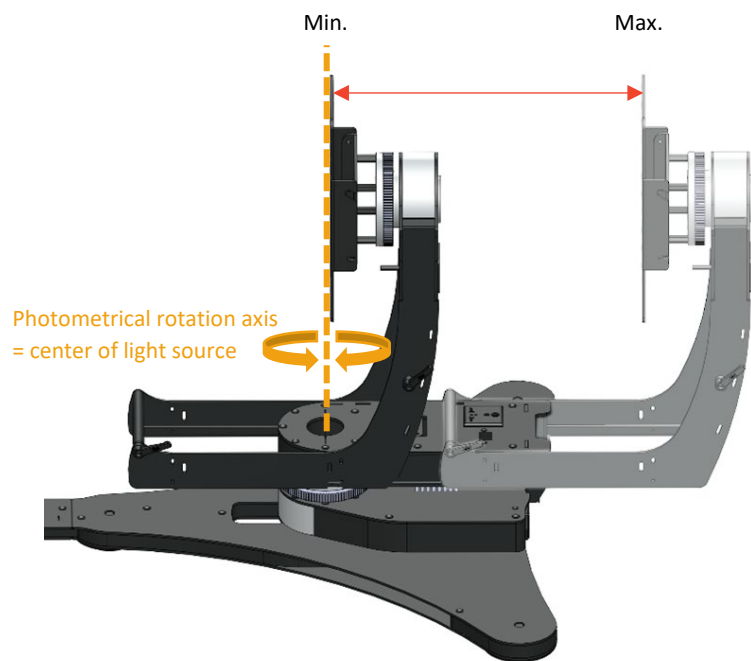
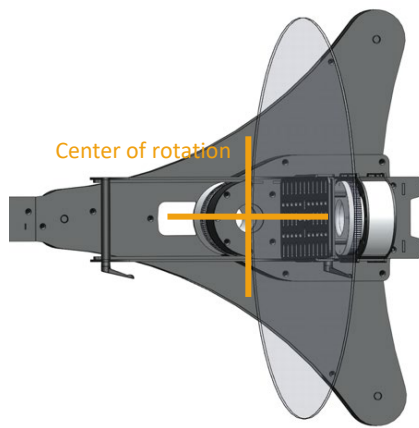

The tower can be adjusted from 0 cm to a max lamp depth of 35 cm.

Run the light source power cord through the holes in the rotors to prevent obstruction of rotation:

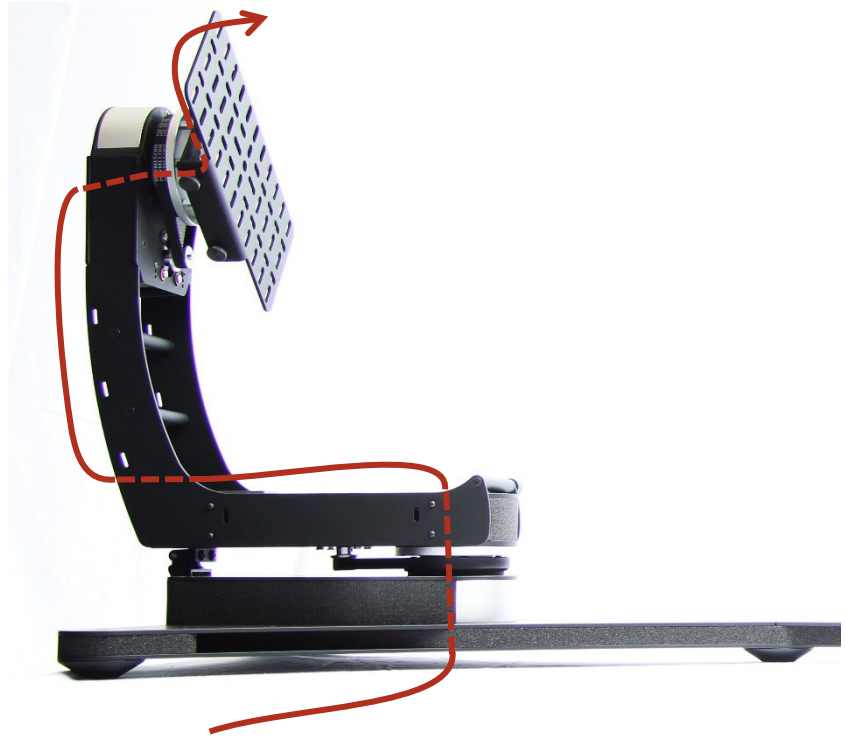

## 12. Mounting of Fixtures with a Static Base

To keep the BaseSpion goniometer still, when mounting and aligning a light source for measurement there is a lock on the back of the goniometer.

A sensor detects when the base is locked and if a measurement is started with the lock activated an animated message will appear in the software, reminding you to unlock the base before continuing.

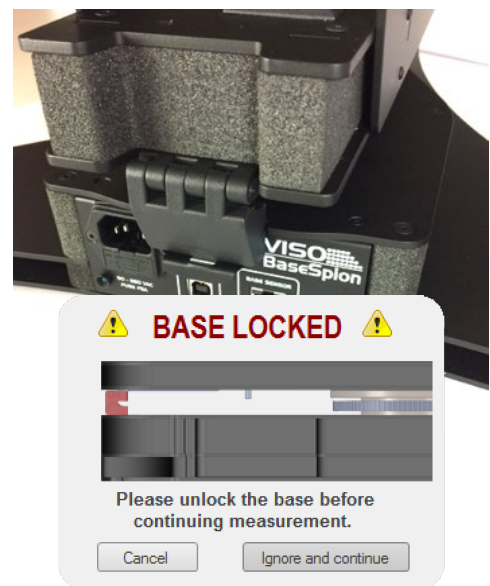

---

## 13. Making Measurements

Please see the descriptions in the software manual in the section called "A Normal Measurement Cycle":

[https://data.visosystems.com/content/manuals/light\\_inspector\\_user\\_manual.pdf](https://data.visosystems.com/content/manuals/light_inspector_user_manual.pdf)

## 14. Attaching the E27 Lamp Holder

Loosen the brass bolt at the end



Put cable plug, brass bolt and the small loose bracket through the C-Plane head

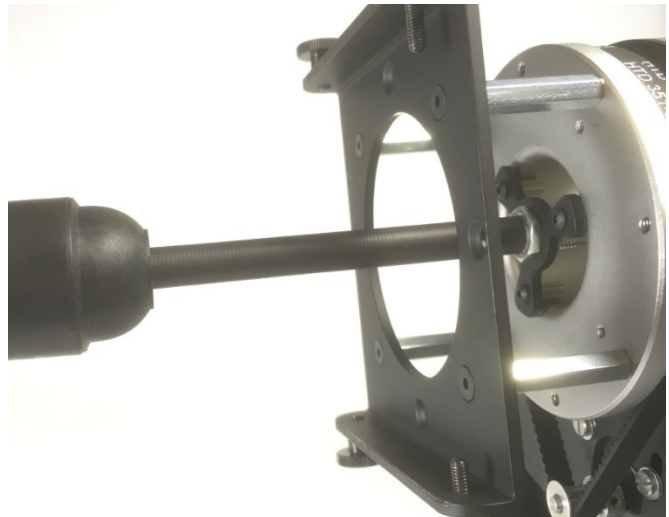

Tighten the brass bolt on the back



## 15. BaseSensor sensitivity range

BaseSensor with Hamamatsu sensor S11639-01

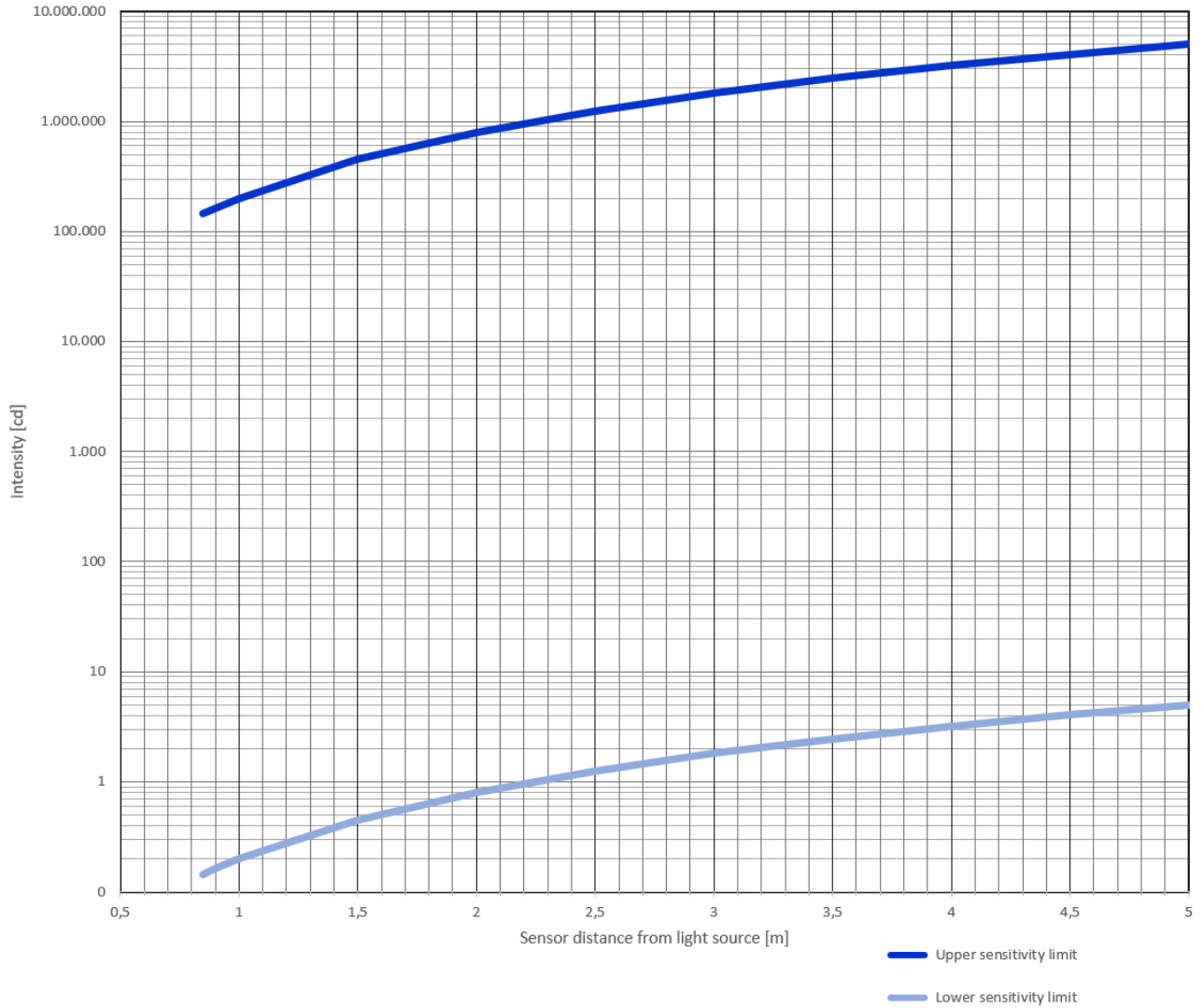

## 16. Specifications

Measurement method

Far Field, Type C

### Physical Dimensions

Shipping dimensions (L x W x H)	<a href="#">See page 6</a>
Shipping weight	41 kg
Dimensions (L x W x H)	<a href="#">See page 5</a>
Weight	38 kg
Sensor distance	0.35 – 4.5 m (minimum 8 x lamp diameter)
Sensor distance setup	Automatic detection on sensor rail
Lamp diameter range	0 – 54 cm
Lamp maximum weight	9 kg

### Electrical

Power supply input	90 - 260 VAC, 50/60 Hz
Power consumption	60 W (Idle 15 W)
USB current consumption	200 mA
Power analyzer voltage range	90 VAC - 260 VAC <+/- 0.5V
Power analyzer current range	0 – 3 A (Avg: +/- 0.5 mA)
Power analyzer power range	0 – 300 W (Avg: +/- 0.1 W)
Power analyzer sample rate	70,000 samples/sec

### Photometric

Illuminance range, lux @ 1m	0.2 – 200,000 <+/- 2,5%
Flux, Lumen @ 0,35 m (Lambertian distr)	0.08 – 75,000 <+/- 4%
Flux, Lumen @ 0,5 m	0.16 – 155,000 <+/- 4%
Flux, Lumen @ 1 m	0.63 – 630,000 <+/- 4%
Flux, Lumen @ 4.5 m	12.7 – 12,700,000 <+/- 4%
Intensity, candela @ 0,35 m	0.0245 – 24,500 <+/- 2,5%
Intensity, candela @ 0,5 m	0.05 – 50,000 <+/- 2,5%
Intensity, candela @ 1 m	0.2 – 200,000 <+/- 2,5%
Intensity, candela @ 4.5 m	4 – 4,050,000 <+/- 2,5%
Color temperature	1,000 K-10,000 K <+/- 35 K
Color rendering index	0-100 <+/- 0.7
Angular resolution BASIC MODE	5-degree step (About 20 sec measurement time per C-plane)
Angular resolution HIGH MODE	1-degree step (About 1 min measurement time per C-plane)
Angular resolution - highest resolution	0,1-degree step (About 5 min measurement time per C-plane)
Spectrometer	Ibsen Photonics FREEDOM (Custom Viso high sensitive transmission grating)
Spectrometer range	360 - 830 nm (1024 pixels)
Spectrometer detector	Hamamatsu S11639-01
Calibration	Fully calibrated with certificate
Re-calibration	Every 1 year (Maximum 2 years)

---

## Control and interface

Control interface	USB 2.0
Control connector	USB-B)

## Connections

AC power in (power supply)	IEC 3-pin
AC power out lamp	Universal socket
Light source adaptor	E27, E14, B22, GU10
PC	USB A

## Approvals

Power supply	cUL/UL, CE, CCC, TUV, FCC
Power analyzer – BaseSensor	CE

## Warranty

Warranty period	2 years
-----------------	---------

## Ordering information

Viso BaseSpion	P/N BASESP001
----------------	---------------



## 17. Appendix 2: Laboratory Checklist

### Before measurement

- All hardware is level and connected

---

- Internet connection is on

---

- PC is not occupied with other tasks

---

- Light source (photometric center) is centered with sensor (horizontally)

---

- Light source (photometric center) is centered with rotation axis (vertically)

---

- BaseSpion: Sensor distance is measured with laser (if moved)

---

- Laboratory general lighting is off

---

- Real-time tracking on/off

---

- Light sources is preheated/stabilized

---

- Number of C-planes is adapted to light source

---

- Measurement resolution is adapted to light source

---

- Measurement area is adapted to light source

---

- ....

---

- ....

---

### After measurement

- Flicker measurements added

---

- Library information entered. Photo added

---

- Measurement saved

---

- ....

---

---

At Viso Systems we design, develop and manufacture OEM- and customer-specific goniophotometer solutions. Our mission is to support customers with powerful and yet easy to use control measurements solutions. Products are developed and manufactured in Copenhagen, Denmark.



**Light measurement made easy**